

Programmable AM/FM scanning receiver

with direct keyboard entry system

VHF:30-50/108-136/138-174 MHz UHF:410-512 MHz



PRO-2020

**OWNER'S
MANUAL**

PLEASE READ BEFORE
USING THIS EQUIPMENT

REALISTIC®*

20-112

*TRADEMARKS OF RADIO SHACK  DIVISION, TANDY CORPORATION

TABLE OF CONTENTS

Specifications	3
A Quick Look At Your PRO-2020	4
Preparation For Use	5
Operating Your PRO-2020	5
Receiver Operations Display	5 ~ 7
Searching With Your PRO-2020	7
Error Indications	8
Birdies	8
Mobile Installation	8
Mobile Noise Suppression	9
Before You Call For Help	10
Some Random Notes	11
Block Diagram	13

You'll hear all the action with your new Realistic PRO-2020 Programmable Scanning Receiver! You'll have direct access to 20,480 different frequencies in eight action radio bands—aircraft, ham radio operators and transportation service! And you can program your PRO-2020 to scan up to twenty channels so you won't miss any of the excitement.

The secret to the PRO-2020 is a custom-designed microprocessor—a computer on a chip! The front panel Keyboard lets you easily enter and change frequencies whenever you wish. The microprocessor also gives you special functions not found on other scanning receivers. Curious about what's on the air in your area? The PRO-2020 will automatically "search" frequency ranges of your choice for active stations—you can locate new stations and services easily! And if there's a frequency you're especially interested in, the PRIORITY Key will make sure you never miss a call on it. You can listen or scan other channels and your PRO-2020 will automatically switch to the channel when a call is received on it!

Other features you'll appreciate include Lockout to skip over channels during scanning and fast/slow search and scanning rates.

Your PRO-2020 achieves its superior performance through the use of the very latest in solid-state technology. In addition to the microprocessor, the PRO-2020 includes a phase-locked loop (PLL) IC, 7 C-MOS ICs, 8 integrated circuits, 40 transistors, 45 diodes and a Fluorescent Display.

FEATURES INCLUDE:

- * Covers 30 – 50 MHz (VHF Lo), 108 – 136 MHz (aircraft), 138 – 144 MHz, 144 – 148 MHz (ham radio operators), 148 – 174 MHz (VHF Hi), 410 – 450 MHz (ham radio), 450 – 470 MHz (UHF Lo) and 470 – 512 MHz (UHF Hi) – 20,480 channels!
- * Scan up to 20 channels continuously.
- * Search feature scans frequency ranges for new stations.
- * Priority function means you'll never miss a call on your favorite channel!
- * Large multi-purpose Fluorescent Display shows which channels and frequencies are being scanned, monitored or programmed as well as the status of the Channels.
- * Channel Lockout function with built-in skipper circuit.
- * Two second scan delay function eliminates missed replies.
- * Crystal filter for 1st IF (10.7 MHz) plus ceramic filter for 2nd IF (455 kHz).
- * AC and DC (negative ground) operation.
- * Universal mounting bracket.
- * 9-volt battery backup holds memorized frequencies in case of power failure.

RADIO SHACK LIMITED WARRANTY

This equipment is warranted against defects for 1 year from date of purchase. Within this period, we will repair it without charge for parts and labour. Simply **bring your sales slip** as proof of purchase date to any Radio Shack store. Warranty does not cover transportation costs. Nor does it cover equipment subjected to misuse or accidental damage.

WE SERVICE WHAT WE SELL

For Your own protection, we urge you to record the Serial Number of this unit in the space provided. You'll find the Serial Number on the back panel of this unit.

Serial Number

WARNING: TO PREVENT FIRE OR SHOCK HAZARD, DO NOT EXPOSE THIS RECEIVER TO RAIN OR MOISTURE.

Use of this unit for reception of radio communications not intended for direct reception of the general public may be subject to licencing requirements under the Radio Act of Canada and its regulations. For licencing information consult the department of communications.

SPECIFICATIONS

SEMICONDUCTOR COMPONENTS:	1 LSI Microprocessor system, 1 LSI PLL system, 7 C-MOS ICs, 8 ICs, 40 transistors and 45 diodes.		
RECEIVING SYSTEM:	Superheterodyne with digital synthesizer to receive any of 20,480 programmable frequencies.		
FREQUENCY COVERAGE:	30 – 50 MHz (in 5 kHz steps) 108 – 136 MHz (in 25 kHz steps) 138 – 144 MHz (in 5 kHz steps) 144 – 148 MHz (in 5 kHz steps) 148 – 174 MHz (in 5 kHz steps) 410 – 450 MHz (in 12.5 kHz steps) 450 – 470 MHz (in 12.5 kHz steps) 470 – 512 MHz (in 12.5 kHz steps)		
CHANNELS OF OPERATION:	Any 20 channels in any band combinations.		
SENSITIVITY			
AM: 20 dB Signal-to-Noise ratio at 60% modulation:	108 – 136 MHz	1.0 μ V	
FM: 20 dB Signal-to-Noise ratio at 3 kHz Deviation:	30 – 50 MHz	0.5 μ V	
	138 – 174 MHz	0.5 μ V	
	410 – 512 MHz	1.0 μ V	
SPURIOUS REJECTION:	30 – 50 MHz	50 dB at 40 MHz	
	108 – 136 MHz	50 dB at 122 MHz	
	138 – 174 MHz	50 dB at 160 MHz	
	410 – 512 MHz	Not specified.	
SELECTIVITY:	\pm 9 kHz, –6 dB \pm 15 kHz, –50 dB		
IF REJECTION:	10.7 MHz	80 dB at 154 MHz	
SCANNING RATE:	Fast	9 channels/sec.	
	Slow	4 channels/sec.	
SEARCH RATE:	Fast	9 steps/sec.	
	Slow	4 steps/sec.	
PRIORITY SAMPLING:	2 seconds		
DELAY TIME:	2 seconds		
MODULATION ACCEPTANCE:	\pm 7 kHz		
IF FREQUENCIES:	10.7 MHz and 455 kHz		
FILTERS:	1 crystal filter, 1 ceramic filter		
SQUELCH SENSITIVITY:	Threshold	Less than	1.0 μ V
	Tight	(S+N)/N	25 dB
ANTENNA IMPEDANCE:	50 ohms		
AUDIO POWER:	2 watts maximum		
BUILT-IN SPEAKER:	2½" x 4" 6.5 x 10 cm oval		
POWER REQUIREMENTS:	AC, 120 Volts, 60 Hz, 19 watts DC, 12 – 15 Volts, 10 watts 9-volt battery for Memory back-up		
DIMENSIONS:	3-1/8" x 10-1/4" x 10-5/8" HWD 8 x 26 x 27 cm		
WEIGHT:	7.7 lbs 3.5 kg		

A QUICK LOOK AT YOUR PRO-2020

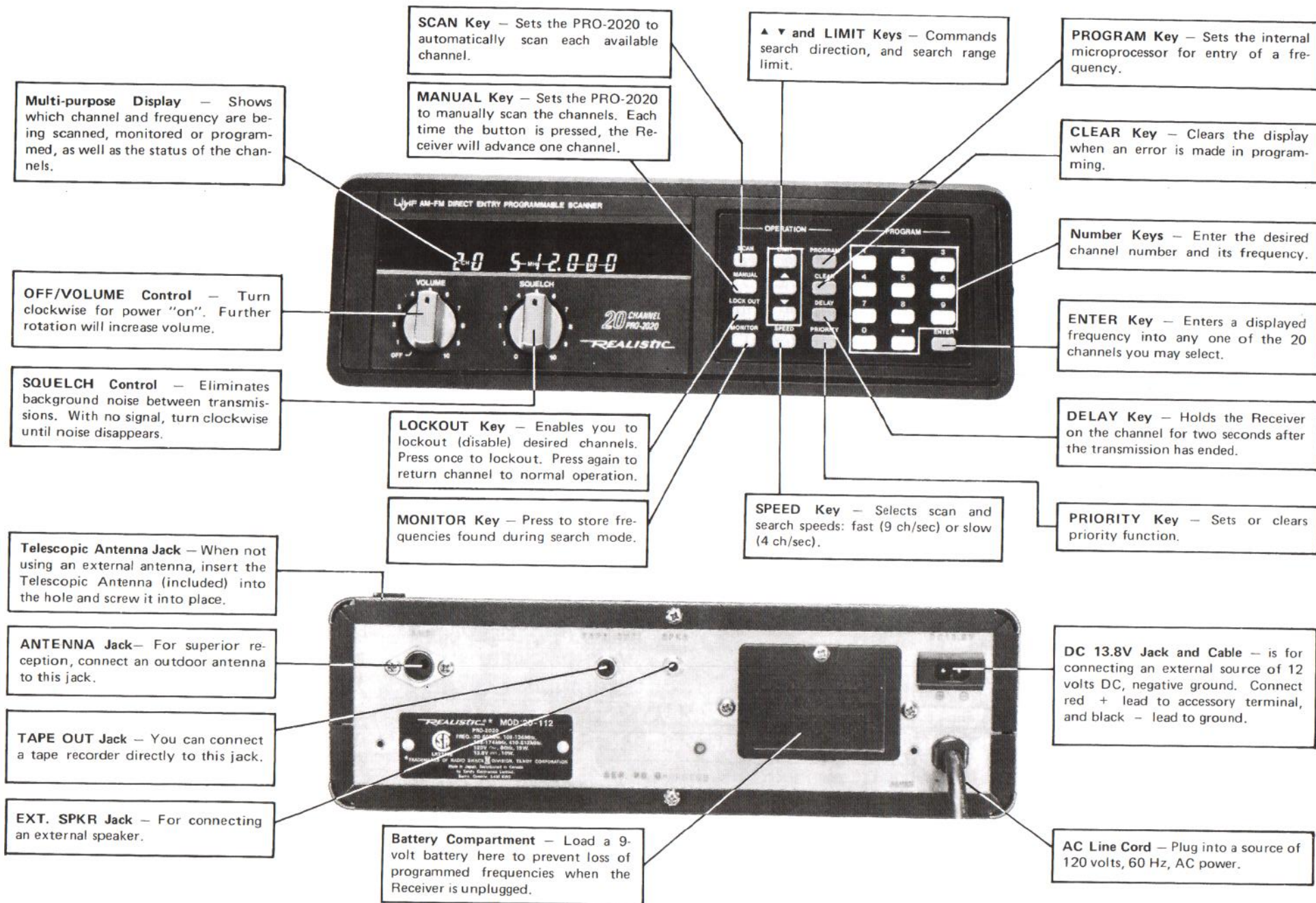

PREPARATION FOR USE

Loosen the screw and remove the battery compartment cover; then snap in a 9-volt battery. (We recommend a Radio Shack long-life alkaline battery, 23-553 or equivalent.) Your PRO-2020 contains an electronic memory to preserve the 20 programmed scanner channels. The battery protects this memory during AC or DC power failure, or when you have the set unplugged.

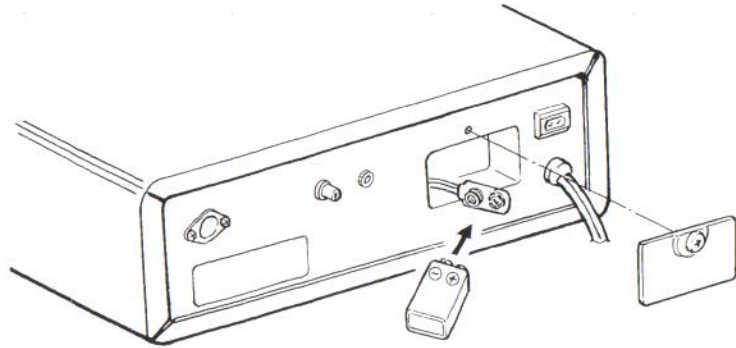

Your PRO-2020 can keep channels stored in its memory for a short period of time even with the AC cord unplugged and the 9-volt battery disconnected. (This is so you can replace the battery with the AC cord unplugged, without losing all the programmed information.) For best results, replace the battery every six months.

CAUTION: Never leave a weak or dead battery in your PRO-2020; even "leakproof" types can leak damaging chemicals. Battery life is about one month when AC or DC power is off for a prolonged period.

Your PRO-2020 comes with a Telescopic Antenna. Insert into the Telescopic Antenna jack on the top of your PRO-2020 and screw into place. Extend to its full length.

For very best reception, you'll need an external antenna. Your local Radio Shack has an excellent antenna for both VHF and UHF reception (Cat. No. 20-014). You can also find mounting hardware, cables and connectors from Radio Shack, too. You'll find that reception improves the higher you mount the antenna.

Connect your Receiver to a standard 120 volt AC wall outlet.

OPERATING YOUR PRO-2020

Turn on your PRO-2020 by rotating VOLUME clockwise. (When first turned on, your PRO-2020 may start scanning.)

Rotate SQUELCH fully counterclockwise. You'll hear a rushing noise from the Speaker. Slowly rotate SQUELCH clockwise until the noise just stops. You're now ready to start entering frequencies!

Understanding the Display

The Fluorescent Display on your PRO-2020 can display the channel number, the frequency being received and special symbols to indicate different functions. Here's a brief rundown on what those symbols mean when receiving stations.

RECEIVER OPERATIONS DISPLAY

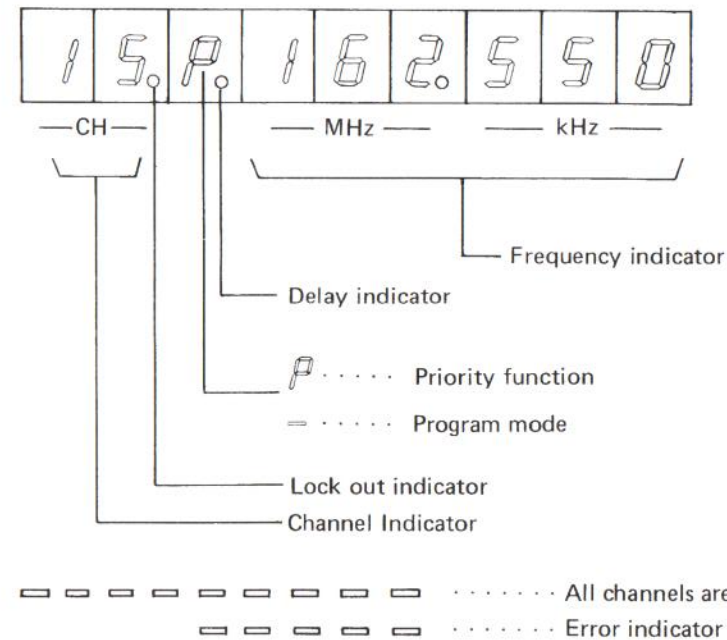

Programming Frequencies

Before programming frequencies, make sure your PRO-2020 is turned on and the SQUELCH is adjusted as we described earlier.

Suppose you want to program channel 1 to receive 162.55 MHz. Here's how you would do it:

1. Press **MANUAL** and select channel 1. You can do this in two ways: press **MANUAL** continuously until the Display indicates channel 1 or by pressing **1** **MANUAL**.
2. Press PROGRAM key.
3. Press the **1** **6** **2** **●** **5** **5** Keys. Check the Display to make sure the frequency it shows is the one you meant to program. If it is, press the ENTER Key.
4. To add more frequencies, just press **PROGRAM** to advance to the next channel and follow the steps above.
5. If you ever want to change the frequency entered for a specific channel, just enter the new frequency "over" the old frequency using steps 1, 2 and 3.

Make a mistake while entering a frequency? Just press **CLEAR**, enter the correct frequency and press **ENTER**. If you're entering a new frequency in place of an old one, the old frequency won't be "erased" when you press **CLEAR**. It will remain stored on that channel until you correctly enter a new frequency and press **ENTER**.

You'll hear a "peep" sound as you press the various keys. This lets you know the key has been properly "entered" into your PRO-2020.

Using the Scanning Function

Your PRO-2020 will automatically scan all the channels you've programmed and stop whenever it finds a signal. To scan channels, just press the **SCAN** Key.

To stop scanning, just press **MANUAL** and you can select specific channels you want to listen to.

Important! Your Pro-2020 won't scan unless SQUELCH is set to the point where no sound is heard if a signal isn't being received.

Delay Function

When your PRO-2020 is scanning, it will stop whenever it finds a signal on a channel. As soon as the signal ends, the scanning function will resume. Most communications heard will be two-way. To make sure you don't miss any replies, press **DELAY**. This will cause your PRO-2020 to stay on a channel for two seconds after the end of a transmission, giving you time to hear any reply. To release the Delay function, just press **DELAY** again. The Delay indicator will show on the Display when the Delay function is used.

Lockout Function

You may want your PRO-2020 to "skip over" certain frequencies while it's scanning (such as continuously transmitted weather broadcasts). To "lock out" such channels, follow these steps:

1. Press **MANUAL** to stop scanning. Continue to press **MANUAL** to advance to channel you want to lock out.
2. When you reach the channel, press **LOCK OUT**. The Display will show **○** to indicate that this channel will be skipped over during scanning.
3. To release the lockout, press **MANUAL** to stop scanning. Advance to channel that is locked out and press **LOCK OUT** once again. **○** will disappear from the Display.



If you use the lockout function on all channels, scanning will be impossible—you'll only be able to change channels using **MANUAL**.

SPEED Selection

Your PRO-2020 will normally scan channels at a rate of four channels per second. If you press **[SPEED]**, channels will be scanned at a rate of nine per second. Press **[SPEED]** again to return to a rate of four channels per second.

Priority Function

You might want to scan other channels yet not miss a call on a channel of particular interest to you (police, fire, ambulance, etc.). The Priority function will let you scan other channels – but if a call is received on the Priority channel, your PRO-2020 will automatically switch to the Priority channel!

1. Only Channel 1 can be used as Priority Channel: Key in the desired Priority frequency into channel 1.
2. Priority function works only when the unit is in Scan or Manual mode.
3. Press **[PRIORITY]** to start Priority function. A  will appear on the Display.
4. Press **[MANUAL]** or **[SCAN]** to listen to other channels. Your PRO-2020 will check the Priority Channel and switch to it if a signal is received on it.
5. To cancel Priority function, press **[PRIORITY]** again. The  will disappear from the Display.

SEARCHING WITH YOUR PRO-2020

One great feature of your PRO-2020 is its ability to “search” for frequencies being used. This means you can hear all the action on the airwaves in your area! To use this great feature, just follow these steps:

1. Press **[PROGRAM]** Key.
2. Press **[LIMIT]** Key. Enter the lower limit of the frequency range to be searched (such as 45.00 MHz). Press **[ENTER]**.
3. Press **[LIMIT]** Key again. Enter the upper limit of the frequency range to be searched (such as 46.00 MHz). Press **[ENTER]**.

4. Press either **[▲]** or **[▼]** to start Search. **[▼]** will start Search from highest frequency and go down while **[▲]** will start from the lowest frequency and go up.
5. You can control the speed of the Search by using the **[SPEED]** Key the same way you use it during scanning.
6. Search will stop when a frequency is found with a signal. To restart Search, press **[▲]** or **[▼]**.

In PROGRAM MODE, search range will be displayed each time **[LIMIT]** is pressed. It is impossible to change the lower frequency only: to change lower frequency you must change higher frequency first. The higher frequency can be changed any time.

Storing Frequencies

If you want to enter some of the frequencies found during Search, do this:

1. Press **[MONITOR]** when your PRO-2020 finds a frequency you want to store.
2. Use **[MANUAL]** Key to select a channel to enter the frequency your PRO-2020 found. The Display will show the frequency currently stored on the channel, but don't worry – the old frequency will be erased when you start to enter the new one.
3. Press **[PROGRAM]**.
4. Press **[MONITOR]** again. The new frequency found during the Search will be displayed.
5. Press **[ENTER]** to put the new frequency into the channel in place of the old frequency.
6. Press either **[▲]** or **[▼]** to resume the Search. To return to Manual or Program operation, press **[MANUAL]** or **[PROGRAM]**. To resume the Search from one of the limit frequencies, press **[LIMIT]** and then **[▲]** or **[▼]**.

ERROR INDICATIONS

Sometimes when you try to enter a frequency for a channel or as a Search range limit, you may find an `-----` on the Display. This means the frequency is in error and you won't be able to enter it into your PRO-2020.

Such frequency errors usually mean you've entered a frequency outside the ranges your PRO-2020 operates on (such as 225.00 MHz) or you've put the decimal point in the wrong place (14.682 MHz instead of 146.82 MHz). Check carefully to find your mistake and then press **CLEAR**. You can now enter the correct frequency.

BIRDIES

Some frequencies may be difficult or impossible to receive. If you program-in one of these, the Scanner may lock up and you hear only noise. These "birdies" are the products of internally generated signals mixing with external signals like TV and FM broadcasts. Telescopic antennas are much more likely to pick up these undesirable signals — that is another good reason for getting an outdoor, base-station type antenna for home installations.

If the interference is not severe, you may be able to use **SQUELCH** to cut out such annoying birdies.

A few of the most common birdies to watch out for are listed below.

30.730 MHz	42.730 MHz	140.800 MHz
}	}	147.200
30.745	42.810	153.600
31.995	44.790	160.000
}	}	166.400
32.125	44.810	172.800
38.395	108.800	
38.400	115.200	
38.405	121.600	
40.975	128.000	
}	134.400	
40.995		

Even with the **SQUELCH** control set to maximum, scanning or searching may stop on or around some of the frequencies listed above. If the spurious signals is strong enough (above 10 μ V in technical terms) you can listen to it, but the Receiver will not auto scan/search.

In case you're wondering . . .

. . . the tuning range of your PRO-2020 is permanently stored in the microprocessor chip. There's no way it can be extended or altered — even by a skilled electronics technician. So if you try to enter a frequency not in the PRO-2020's tuning ranges, you'll get an error message every time! To listen to CB, shortwave or broadcasting bands, you'll need another receiver designed for that purpose (like our famous DX-302 shortwave receiver).

BASE INSTALLATION

In any communications receiver installation, the antenna is one of the most important parts of the set-up. Although the telescopic antenna we've included will be adequate for strong local signals, the best reception will result from a multi-band outdoor antenna. It should be mounted as high as possible since the VHF and UHF signals your Receiver picks up travel in a straight line. The higher your antenna, the better your reception. Your local Radio Shack can help you in the selection of antennas, cables and accessories. (They can also advise you on the most popular frequencies in your area.)



20-014



20-176

MOBILE INSTALLATION

Safety and operating convenience are the primary factors to consider when you install any equipment in a vehicle. Be sure you can easily reach the Receiver's controls. Also, be sure the connecting cables do not interfere with the operation of the vehicle (brake, accelerator, etc.).

You can mount the Receiver to the underside of the dash or instrument panel in the vehicle. Use the universal mounting bracket provided. Take care when drilling holes that you do not drill into existing wires or trim.

The PRO-2020 is designed to operate from a negative ground 12-volt DC source. Be sure you connect power leads with the correct polarity. Use the DC Power cable provided. The other end of these wires (red and black) can be connected to an Auto Cigarette Lighter Plug, Catalog Number 274-331; or you can make the connections directly to the fuse block of the vehicle. Be sure to observe correct voltage polarity: red to "+" and black to "-".

IMPORTANT: If your car has been burning out headlamps and other bulbs at a rapid rate, first have the voltage regulator checked for proper output: excessive voltage (more than 16 volts) can damage your Receiver.

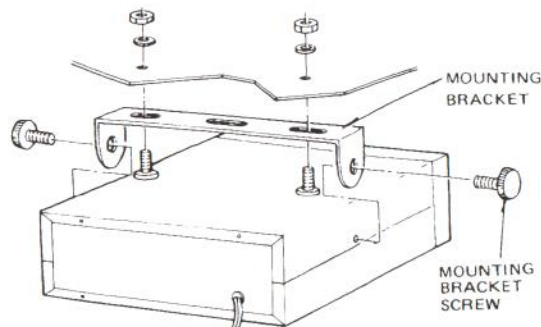

Mobile Antenna

There are many possible mounting locations on a car. Three of the most popular locations for monitoring antennas are shown below.

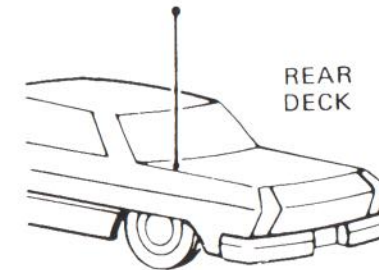
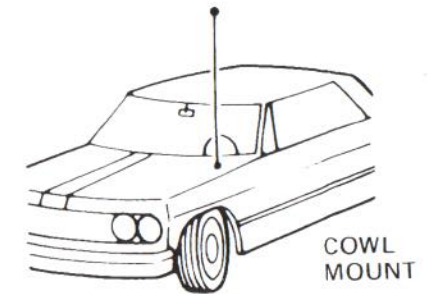
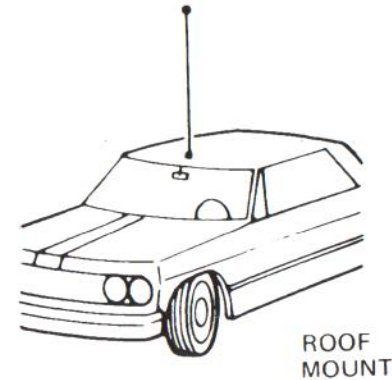

A convenient and efficient antenna for mobile use is Radio Shack's VHF-Hi/Lo UHF-Hi/Lo No-Hole Trunk Mount Mobile, 20-017.

Keep the following points in mind when installing your mobile antenna.

1. Mount it rigidly, so it will remain vertical while in motion.
2. Mount as far as possible from the engine compartment.



20-017

MOBILE NOISE SUPPRESSION

Your PRO-2020 is a very sensitive receiver, and will pick up even extremely weak signals. This means that in addition to the tiny radio signals, radio-frequency noise may also be picked up and amplified.

In a mobile installation, it is important that you take steps to reduce the amount of noise that finds its way into the Receiver. If you take some or all of the steps recommended below, your reception should be quite satisfactory for mobile applications.

Electrical System:

Generally speaking, noise can be generated by any device or connection that carries electrical current. Any device that generates a spark should also be suspected. Bypass any suspected wire to ground with a high quality 1 μ F coaxial capacitor.

A very common source of noise is the generator or alternator. This type of noise will sound like a musical whine, and will also vary with speed of the engine. Generator and alternator noise can usually be reduced by connecting a coaxial-type capacitor from the armature terminal to the metal case.

Ignition System:

The ignition system is the most common source of noise. This noise can be identified by the fact that its speed varies with the engine speed. Ignition noise will sound like a series of "popping" sounds, while the engine is idling, and will speed up to a buzzing sound as engine speed is increased.

There are a number of things that can be done for this type of noise.

1. Use radio suppression-type ignition wire and resistor spark plugs.
2. Check high-voltage wiring for leakage, cracks, etc. Replace any wiring.
3. In extreme cases, obtain an ignition noise suppression kit – it should shield all ignition wiring. This will provide maximum suppression.

BEFORE YOU CALL FOR HELP . . .

The PRO-2020 is a ruggedly built electronic unit, with all parts conservatively rated. However, you should treat it with care; don't subject it to excessively rough handling. You will find it will give you long life if kept free from dirt and excessive humidity.

The 9-volt Battery (used to maintain the program memory) should be replaced every 6 months. Use only an Alkaline type, such as Radio Shack's Catalog Number 23-553.

If you Have Problems

We hope you don't – but if you do, here are some suggestions.

Problem	Possible Cause
Inoperative	No power – check to see that unit is plugged into a working AC outlet, or DC power source.
Will not scan	1) All channels are locked out. 2) Squelch control is not adjusted right.
Scan locks-in on frequencies where no clear signal is present	"Birdies" – see list on page 8.

If none of these suggested remedies solves the problem, return your set to your nearby Radio Shack. It will be repaired by a qualified technician and you'll have it back ASAP!

SOME RANDOM NOTES

You'll soon notice some differences between reception on the aircraft band (108 – 136 MHz) and the other ranges covered by your PRO-2020. Aircraft band stations use AM, while stations on the other ranges covered by your PRO-2020 use FM. Don't be too surprised if reception is a bit "noisier" on the aircraft band than others. Your PRO-2020 will automatically switch over to AM or FM depending on the frequency you wish to listen on.

Reception on the frequencies covered by your PRO-2020 is mainly "line of sight." That means you usually won't be able to hear stations located beyond the horizon at your listening location. You'll be able to hear aircraft at greater distances than ground stations. And during the summer months you may be able to hear stations in the 30 – 50 MHz range located several hundred or even thousands of miles away. This is due to summer atmospheric conditions; this type of reception is unpredictable (but often very interesting!).

One very useful service is the National Weather Service's continuous weather broadcasts. These broadcasts contain weather forecasts and data for the area around the station plus bulletins on any threatening weather conditions. These stations use three frequencies – 162.40, 162.475 or 162.55 MHz. In most areas of the country you will be able to receive one of these frequencies.

BLOCK DIAGRAM

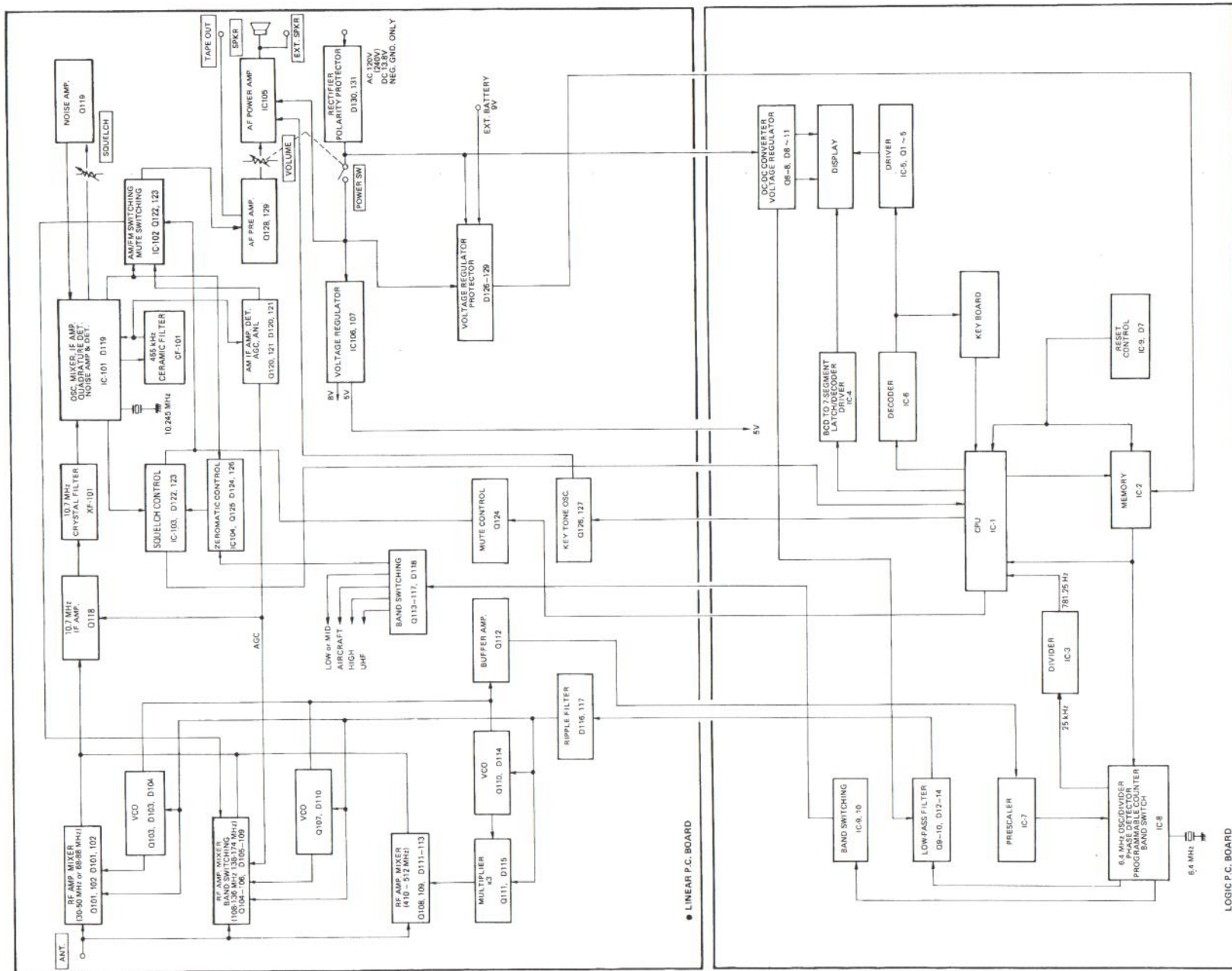

RADIO SHACK  DIVISION, TANDY ELECTRONICS LIMITED

**CANADA: BARRIE, ONTARIO L4M 4W5
U.S.A.: FORT WORTH, TEXAS 76102**

TANDY CORPORATION

AUSTRALIA

280-316 VICTORIA ROAD
RYDALMERE, N.S.W. 2116

U.K.

BILSTON ROAD
WEDNESBURY, WEST MIDLANDS WS10 7JN

BELGIUM

PARC INDUSTRIEL DE NANINNE
5140 NANINNE